

MGB Plastics

240L Wheelie Bin

Part of MGB's wheeled bin package. All fully manufactured & tested in the UK to the strictest standards



Part of

Egbert Taylor
Middle East

MGB Plastics 240L

The MGB 240L wheeled bin can be found in its multi-millions on doorsteps throughout the country, from Lands End to John O'Groats! The MGB 240L wheeled bin is class leading & the highest selling bin in the UK, fully made in the UK. It is modern, robust & fully customisable. Fully manufactured in the UK on our state of the art equipment & can be fully customised to the customers colour & marking requirements & MGB represent exceptional customer service along with class leading value for money.



Features

- EN840: 2012 approved & certified
- Drop tested on a daily basis/ RAL tested
- Tested to the very highest European standards
- Large print area on body and lid for customer logo and/or information
- Sequential Numbering, RFID tag compatible
- Strengthened front rim to ensure exact locking on lifting equipment
- Solid rubber tyres with steel spring loaded locking pins
- Rounded corners and smooth easy to clean internal surfaces
- Fully compatible with all inner caddies

Options

- Colour (to client specification)
- Embossed logos
- RFID tagging
- Labelling & recycling information
- Lids are adaptable for promotions
- Tactile bins compliant with the RNIB
- Venting
- Available as 120L, 140L & 180L

Technical Details

| | | | |
|----------------|---------------|------------------------|-------------------|
| Height: | 1057mm | Capacity: | 240 Litres |
| Width: | 580mm | Empty Weight: | 9.7kg |
| Depth: | 715mm | Wheel Diameter: | 200mm |

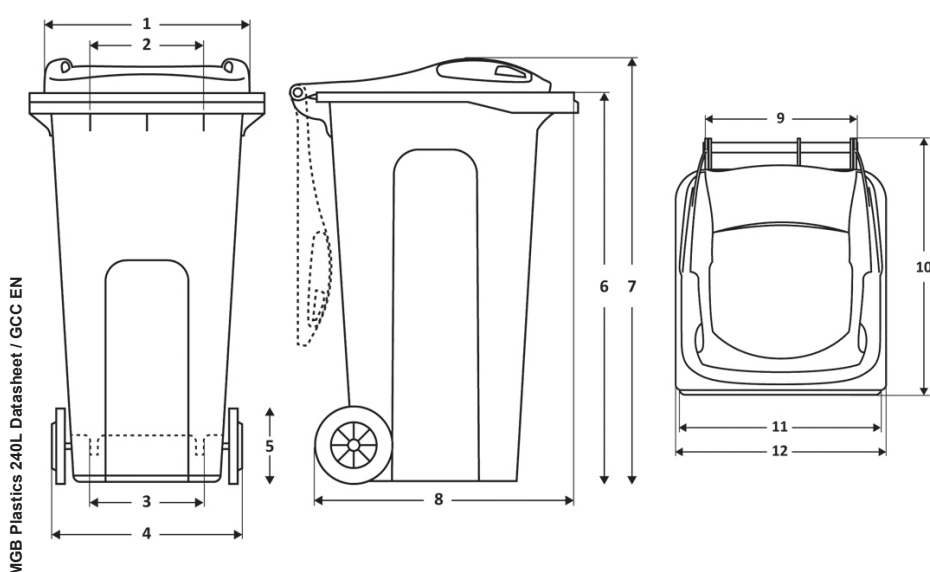

| Position | Dimension (mm) |
|----------|----------------|
| 1 | 550 |
| 2 | 290 |
| 3 | 355 |
| 4 | 565 |
| 5 | 200 |
| 6 | 969 |
| 7 | 1050 |
| 8 | 640 |
| 9 | 415 |
| 10 | 715 |
| 11 | 577 |
| 12 | 577 |

Talk to us
+44 (0)4 3791711

Email us
info@egberttaylor.ae

Visit us online
www.egberttaylor.ae