

Continental™

700L



The latest edition to the Continental™ family, the 700 litre waste container is ideal for your medium to large collection needs where space is limited, which is suitable for towing.



Part of

Egbert Taylor

Continental™ 700L

With the same footprint as our 660 container, the addition of a sump base creates extra storage capacity whilst offering exceptional towing stability due to its specialised design.

The 700 waste container as with all the Continental™ range is fully EN840 certified ensuring superb quality and safety. The 700 is ideal for narrow access and towing.



Features

Featured as standard on all Continental™ 700's:

- EN840 compliant
- Internally seam welded
- Hot dip galvanised body
- Welded comb bar
- 20mm top frame
- 2 x swivel castors & 2 x braked castors
- Robust steel hinge
- Transfer through doors
- Facility for ID chip
- Area for logo & decals
- 160mm castors

Options

- DIN points
- Custom embossing
- Central locking castors
- Drop front / drop back panel
- Tag safe
- Towing capabilities
- Drain plug options
- Different lid types & apertures
- Variety of lid colours
- Powder coated body colour options
- Locking options
- Security solutions
- Sound deadening

Technical Details

Height:	1320mm	Capacity:	700 litres
Width:	1250mm	Empty Weight:	85kg
Depth:	720mm	Castors:	200mm

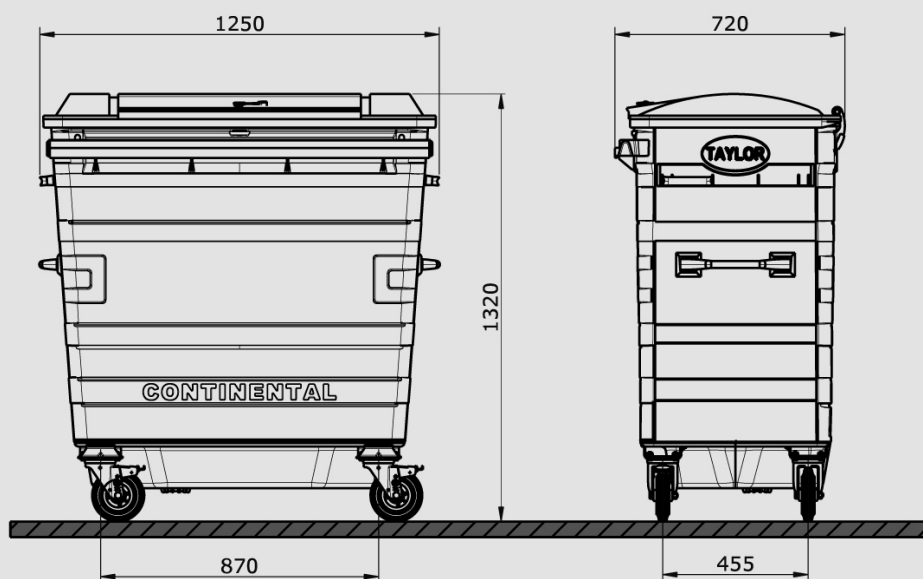

Continental™ 700L Datasheet / UK EN

Talk to us

+44 (0)1299 251 333

Email us

info@egberttaylor.com

Visit us online

www.egberttaylor.com

Egbert H. Taylor & Co Ltd, Oak Park, Ryelands Lane, Elmley Lovett, Droitwich, Worcestershire, WR9 0QZ, UK

Egbert H. Taylor & Co Ltd is a limited company registered in England and Wales. No. 00718441. Registered Office as above.