

# Continental™

## 820L



The Continental™ 820 litre is ideal for your medium to large collections where space is limited. Same footprint as our 770, the sump base creates extra storage capacity whilst retaining the same superb towing capability as the smaller model.



Part of

# Egbert Taylor

# Continental™ 820L

Internally Welded seams prevent internal corrosion, whilst the hard wearing galvanised steel body and base make for a durable, long lasting container that delivers exceptional lifetime value when compared to plastic or alternative steel containers.

The 820 is also available in a drop front variant to allow easy transfer of waste to and from the container and as with all the Continental™ range it is fully EN840 certified and UN approved ensuring superb quality and safety.



## Features

Featured as standard on all Continental™ 820's:

- EN840 compliant
- Internally seam welded
- Hot dip galvanised body
- Welded comb bar
- 20mm top frame
- 2 x swivel castors & 2 x braked castors
- Robust steel hinge
- Narrow frame bin
- 200mm castors

## Options

- DIN points
- Custom embossing
- Central locking castors
- Drop front / drop back panel
- External / internal fork pockets
- Heavy duty castors
- Heavy duty towing
- Tag safe
- Towing capabilities
- Drain plug options
- Powder coated body colour options
- Locking options
- Security solutions
- Sound deadening
- Central locking
- UN certified

## Technical Details

Height:	1360mm	Capacity:	820 litres
Width:	1250mm	Empty Weight:	92kg
Depth:	785mm	Castors:	200mm

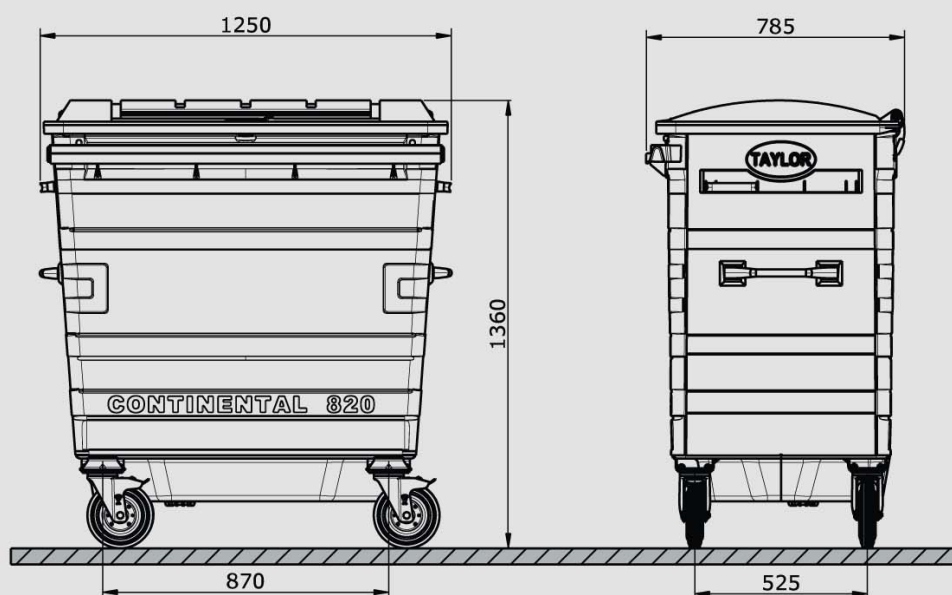

Continental™ 820L Datasheet / UK EN

### Talk to us

+44 (0)1299 251 333

### Email us

info@egberttaylor.com

### Visit us online

www.egberttaylor.com

**Egbert H. Taylor & Co Ltd**, Oak Park, Ryelands Lane, Elmley Lovett, Droitwich, Worcestershire, WR9 0QZ, UK

Egbert H. Taylor & Co Ltd is a limited company registered in England and Wales. No. 00718441. Registered Office as above.